

Netting / Meat Stuffer



Designed for the filling of meat / muscles into netting and foil together. Options include single headed and twin headed versions

NM Meat Stuffer

Netting / Meat Stuffers

Construction Advantages:

- Stainless steel construction
- Pneumatic system
- Optimal filling ham sizes
- High production efficiency
- Possibility of using different netting / casing diameters
- Upper casing / netting holder
- Optional automatic net spinner
- 140-200mm filling horn

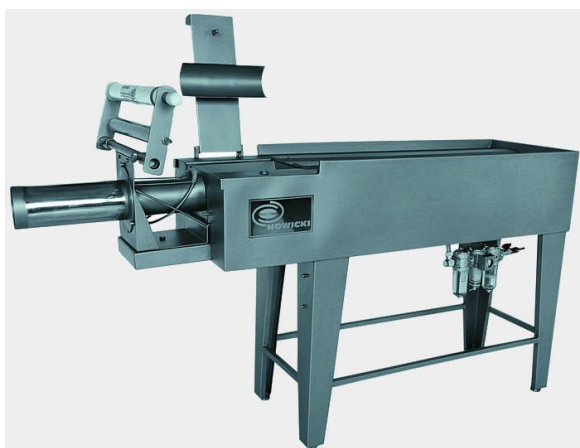

Type of Meat Stuffer		NM- 2K	NM- 3K
Range of funnel diameters	mm	80 ÷ 140	80 ÷ 140
Dimensions: Length	mm	1850	2050
Width	mm	650	1550
Height	mm	1160	1250
Weight	kg	76	150

