

### For 600 Litre Containers (Stationary Model)

Designed for easy unloading of different products in a stationary position.

#### Features:

- Fixed discharge chute designed to suit.
- Stationary, for floor fixing.
- High quality hydraulic pack and motor.
- Stainless steel hydraulic cylinder.
- Heavy duty construction.
- Stainless steel, grade 1.4301(AISI 304)
- CE & USDA compliant.
- Special executions on request.

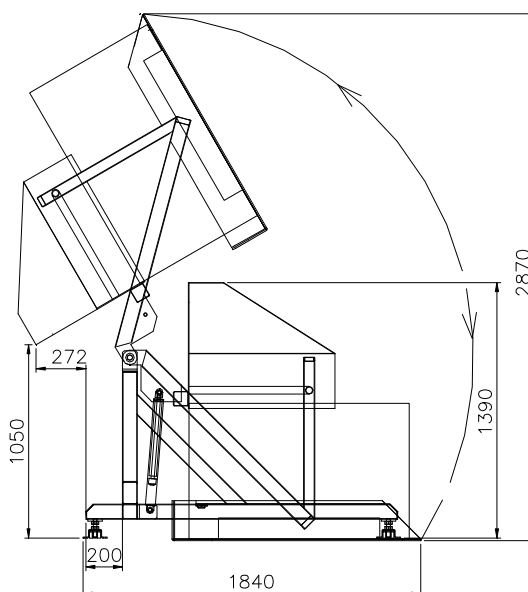

#### Technical Data

Power supply:	400 V 50 Hz
Control voltage:	24 V DC
Power consumption:	1,1 kW
Fuse:	10 A
Capacity:	max. 650 kg
Tilting time:	approx. 20 sec.
Tilting height:	max. 1050 mm
Total height by tilting:	max. 2870 mm
Machine weight:	approx. 400 kg
Machine dimensions:	1833 x 1808x 1390 mm
Pallet dimensions:	2150x 2100 x 1600 mm

