

Technical Data Sheet

Swing Loader for 700 Litre Containers And 200L Eurobins

Art No 2.481.105



Dual purpose Swing Loader for emptying 700 Litre containers and 200 Litre Eurobins

Designed for unloading of 700 litre containers 1100x900x895 mm and standard Eurobins/Tote bins made to DIN 9797

Designed for easy unloading of different products, with built-in chute designed according to the specific requirements.

Features:

- . In stationary execution.
- Hydraulic power pack.
- Stainless steel cylinder.
- Heavy duty construction.
- Stainless steel, grade 1.4301. (AISI 304)
- CE and USDA compliant.
- Special executions on request.



Technical Data:

Power supply:	400V 50 Hz
Control voltage:	24 V DC
Power consumption:	1,1 kW
Fuse:	10 A
Capacity:	max. 800 kg
Tilting time:	approx. 20 sec.
Tilting height:	max. 1305 mm
Total height by tilting:	max. 3139 mm
Machine weight:	approx. 450 kg
Machine dimensions:	2092x 1644 x 1610 mm
Pallet dimensions:	2300 x 1900 x 1800 mm

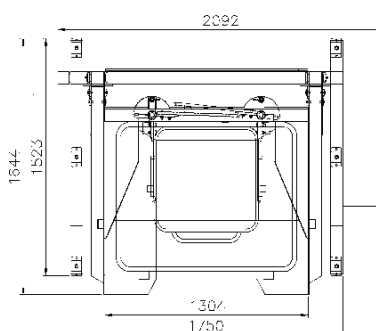
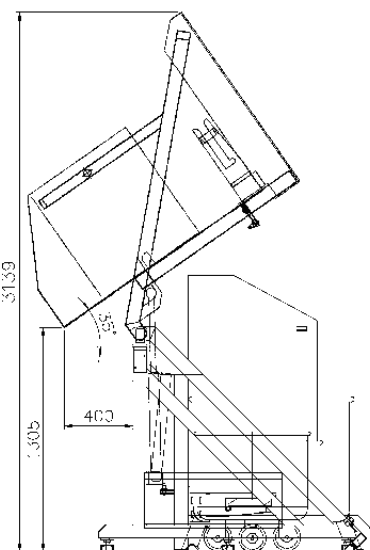

All machines are subject to continuous improvement

