

3040

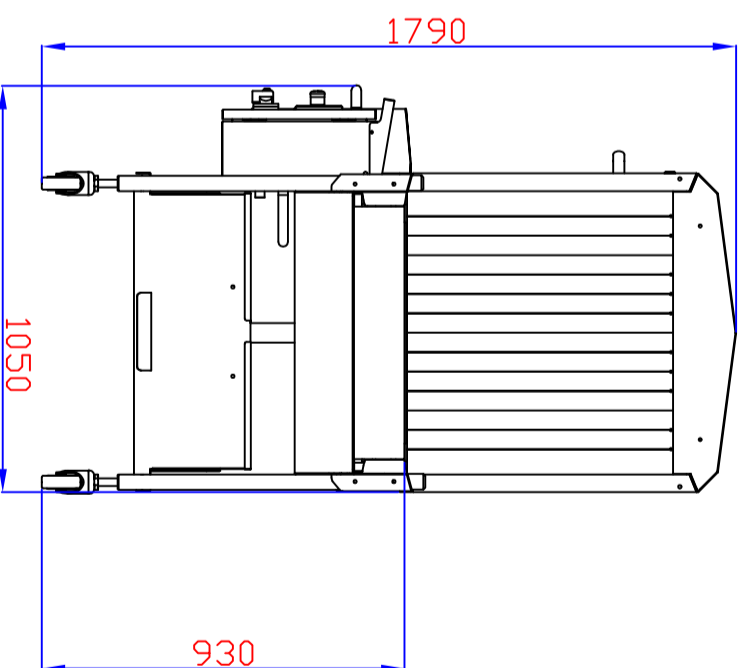

Height Adjustable +/- 50 mm

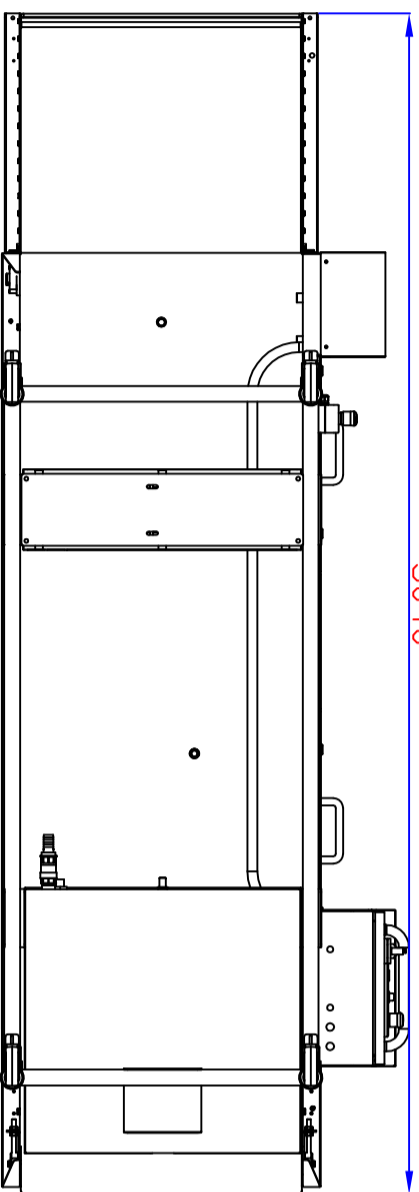
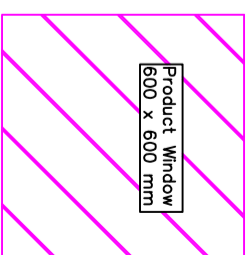

**Dantech UK Ltd**  
 Merlin Park  
 Ringhill Road, Buncough,  
 Lancashire L40 8JY  
 Great Britain  
 Tel: +44 (0)945 127 9080  
 Fax: +44 (0)945 127 9081  
 Email: sales@dantechuk.com  
 www.dantechuk.com

PROJ.  
 CAD / COMMENT  
**ACAD**

Client  
**Sanitizer Tunnel**  
 Model 6450.01

MATERIAL	St Steel 1.4301 (304)		FORMAT	A3	ITEM	
LAST REV. DATE	SIGN.	APPD.	MASS [kg]			
DATE	SIGN.	APPD.	SCALE	1:20	DRAWING NO.	6450.-01
Nov 2013	CT					REV.

WARNING: PROPRIETARY AND CONFIDENTIAL INFORMATION. This document and the information set forth herein (the "Information") are confidential and proprietary to Dantech UK Ltd ("Dantech"), constitute trade secrets and derive independent economic value, actual or potential, from not being generally known. In consideration of your receiving this document you agree (i) to keep the Information secret, (ii) only to use the Information for your own needs to accomplish the task(s) agreed with Dantech, (iii) not to disclose any part of the Information to any third party and (iv) not to make copies or reproductions thereof by whatsoever means.